

Australian Gas Networks, AGI Tanami Pty Ltd and Multinet Gas Distribution Partnership - User Access Guide



Table of Contents

1. REQUIREMENTS OF A USER ACCESS GUIDE.....	3
2. WHO ARE YOU DEALING WITH.....	4
3. CONTACT DETAILS	6
4. ACCESS REQUEST PROCESS.....	7
5. FURTHER INVESTIGATIONS	9
6. NEGOTIATIONS & ARBITRATION	11
7. CONFIDENTIALITY	10
8. INTERCONNECTION POLICY	14
APPENDIX A: ACCESS REQUEST FORM.....	15
APPENDIX B: INTERCONNECTION POLICY	17

1. REQUIREMENTS OF A USER ACCESS GUIDE

The National Gas Rules requires a service provider to develop and maintain a user access guide that contains information for each of its pipelines (which includes both gas transmission pipelines and gas distribution networks).

This user access guide has been developed by Australian Gas Networks Limited (“**AGN**”) for pipelines for which AGN (or one of its subsidiaries) is the service provider, AGI Tanami (“**AGIT**”) for the Tanami gas pipeline in the NT (TNP) and by the Multinet Gas Distribution Partnership (“**MGN**”)¹ for pipelines for which it is the service provider.

This guide has been designed to be a one stop guide to help you obtain access to services on our pipelines and networks. The guide sets out the following:

- A list of our gas transmission pipelines;
- A list of our gas distribution networks;
- Contact details for our gas transmission and gas distribution teams;
- The process for making an access request on our gas transmission and distribution networks;
- The fees and charges for making a request; and
- The interconnection policy applicable to our pipelines and networks.

Through this guide we will direct you to the asset and the team that will best meet your requirements.

While we are required by law to make certain information available², this guide has been prepared to facilitate the process for securing access to the sort of service that you are seeking.

If, however, at any time you are unsure about anything, we encourage you to contact our commercial team on the contact details outlined in Section 3.

1 The Multinet Gas Distribution Partnership is a partnership between Multinet Gas (DB No 1) Pty Ltd and Multinet Gas (DB No 2) Pty Ltd.

2 NGR 105C outlines the information that is required in a user access guide.

2. WHO ARE YOU DEALING WITH

There are different entities you will deal with, depending on the pipeline or network you are seeking to access a pipeline service. The tables below list the names of the entities of our pipelines and networks.

However, we are all part of one group, any enquiry can be directed to the contacts provided in Section 3 of this guide.

Transmission Pipelines

State	Pipeline	Service Provider	Regulatory Scheme
NSW	Illabo to Tumut Pipeline	Australian Gas Networks (NSW) Pty Ltd	Non-scheme
NT	Palm Valley to Alice Springs Pipeline	Australian Gas Networks Limited	Non-scheme
NT	AGI Tanami	AGI Tanami Pty Ltd	Non-scheme
QLD	Wide Bay Pipeline	Australian Gas Networks Limited	Non-scheme
QLD	Bundaberg Port Gas Pipeline	Australian Gas Networks Limited	Non-scheme
SA	Riverland Pipeline System	Australian Gas Networks (SA) Limited	Non-scheme
VIC	South Gippsland Pipeline	Multinet Gas Networks	Non-scheme

Distribution Networks

State	Network	Service Provider	
NSW	AGN Albury Gas Distribution Network	Australian Gas Networks (Albury) Pty Ltd	Scheme
NSW	Wagga Wagga Distribution Network	Australian Gas Networks (NSW) Pty Ltd	Non-scheme
NSW	Monaro Distribution Network	Australian Gas Networks (NSW) Pty Ltd	Non-scheme
NSW	Riverina Distribution Network	Australian Gas Networks (NSW) Pty Ltd	Non-scheme
NSW	Illabo to Tumut Valley Towns system	Australian Gas Networks (NSW) Pty Ltd	Non-scheme
NSW	Moama Distribution Network	Australian Gas Networks (Albury) Pty Ltd	Non-scheme
NSW	Murray Valley Distribution Network	Australian Gas Networks (Albury) Pty Ltd	Non-scheme
NSW	Tamworth Gas Network	Tamworth Gas Network Pty Ltd	Non-scheme
NT	Alice Springs Distribution Network	Australian Gas Networks Limited	Non-scheme
QLD	AGN Qld Gas Distribution Network (Brisbane (north of the Brisbane River), Ipswich, Gladstone and Rockhampton)	Australian Gas Networks Limited	Non-scheme
QLD	Grantham Gas Pipeline	Australian Gas Networks Limited	Non-scheme

QLD	Wide Bay Distribution Network	Australian Gas Networks Limited	Non-scheme
SA	AGN SA Gas Distribution Network	Australian Gas Networks Limited	Scheme
SA	Murray Valley Distribution Network	Australian Gas Networks Limited	Non-scheme
VIC	AGN Vic Gas Distribution Network	Australian Gas Networks (Vic) Pty Limited	Scheme
VIC	Mildura Distribution System	Australian Gas Networks Limited	Non-scheme
VIC	Multinet Gas Distribution Network	Multinet Gas Distribution Partnership	Scheme
VIC	Murray Valley Distribution Network	Australian Gas Networks (Vic) Pty Limited	Non-scheme

3. CONTACT DETAILS

This section outlines the contact details you should contact to make preliminary enquiries and to whom access requests can be sent. The relevant contract details are set out for both transmission pipelines and distribution networks.

Transmission Pipelines

Head of Commercial Operations (AGI)
Level 22, 140 St Georges Terrace, Perth, WA, 6000
Postal address: As above
Tel: (08) 9223 4300
Fax: (08) 9223 4301
Notices@agig.com.au
[Website: www.agig.com.au](http://www.agig.com.au)

Distribution Networks

Commercial Manager
Level 6, 400 King William Street, Adelaide, SA, 5000
Postal address: As above
Tel: (08) 8227 1500
Fax: (08) 8227 1511

grant.macauley@agig.com.au
[Website: www.agig.com.au](http://www.agig.com.au)

4. ACCESS REQUEST PROCESS³

Making a Preliminary Enquiry

If you require access to a service on one of our pipelines or networks, you may make a preliminary enquiry by discussing your requirements with our contact person in Section 3 of this guide.

Making preliminary enquiries can help you gather additional information about our pipelines and networks and help you decide whether you wish to complete an access request form. You are not required to make a preliminary enquiry.

If you make a preliminary enquiry, we will respond to that preliminary enquiry within 10 business days stating:

- (a) whether we can provide access to the pipeline services referred to in the enquiry or whether we need to carry out further investigations; and
- (b) when we will provide an offer.

We may also inform you of any reasonable costs that you may need to pay for any investigations we will need to undertake and the timeframe for those investigations.

Making an Access Request

You may at any time submit an access request for one of our pipelines or networks by following the process outlined in this section.

An access request must be submitted using the form in Appendix 1 of this Guide and must contain the information specified in that form.

We will acknowledge receipt of an access request within 5 business days after it is received. If your access request is complete, it will be a Complying Access Request.

If your access request is incomplete, the acknowledgment will specify the information required to complete the access request. Once you have provided the specified information, we will tell you within five (5) business days whether it is a Complying Access Request.

We will notify you within 10 business days of receiving a Complying Access Request if we need to undertake further investigations in relation to your access request and we will outline what further investigations are required (See Section 5).

You may amend the details of the Complying Access Request with our consent. We must not unreasonably withhold our consent to a request to amend but may give consent subject to reaching agreement on a reasonable extension to the period for us to make an access offer.

Access Offer

Following receipt of a Complying Access Request, if we have not advised you that we need to undertake further investigations in relation to your access request, we will prepare an access offer that:

- sets out the terms and conditions on which we offer to make the pipeline service or pipeline services requested in the access request available to you (including price and non-price terms and conditions);
- contains the details of any works to be undertaken by us and you (where relevant) and any applicable technical and performance specifications; and
- be in a form capable of acceptance by you so as to constitute a new access contract or to form

³ Under NGR 105C(6)(c), the User Access Guide must describe the process for making an access request, the information to be included with the access request (subject to subrule (7)) and response times

part of an existing access contract.

The access offer will most likely be in the form of a proposed gas transportation or haulage agreement, but it may contain other documents that require execution.

We must make you an access offer within the period agreed by us or if no period is agreed between us:

- (a) unless paragraph (b) or (c) applies - within 20 business days after receiving the Complying Access Request;
- (b) if we are required to carry out further investigations in relation to your access request - within 60 business days after receiving the Complying Access Request; and
- (c) if you make any amendment to the Complying Access Request before we make you an access offer – within 20 business days after receiving the amended Complying Access Request or any longer period that is agreed between us as a condition of our consenting to the amendment to the Complying Access Request.

We are however, not required to make an access offer in relation to a pipeline service if:

- (a) the Complying Access Request has been withdrawn;
- (b) we have concluded that it is not technically feasible or consistent with the safe and reliable operation of the pipeline to provide the pipeline service requested by you, having used all reasonable efforts to accommodate your reasonable requirements; or
- (c) the provision of the pipeline service requested by you would require the extension of our pipeline or network.

If we do not make an access offer because of any of the circumstances specified above, we will give you:

- (a) written reasons explaining why the requested pipeline service cannot be provided; and
- (b) if there is some prospect that it will become possible to provide the requested pipeline service at some time in the future – details of when the requested pipeline service is likely to become available.

Accepting an Access Offer

If we make an access offer, it will remain valid for up to 30 business days.

If you wish to accept the access offer and it is in the form of a gas transportation or gas haulage agreement, you must execute every copy that was included in the access offer and return each signed copy to our contact person in Section 3 of this guide.

We will then proceed to execute and date each copy of every agreement and send you a copy of each agreement for your records.

You are not required to accept the access offer that we make to you. If you do not wish to accept our access offer, you may take one of the following steps:

- (a) notify us in writing (by advising the contact person identified in Section 3 of this guide) that you do not accept the offer and that you no longer wish to continue discussions in relation to the access offer or the Complying Access Request;
- (b) notify us in writing (by advising the contact person identified in Section 3 of this guide) that you wish to enter into negotiations regarding access to our pipelines; or
- (c) notify us in writing (by advising the contact person identified in Section 3 of this guide) that you intend to refer an access dispute to arbitration under the National Gas Law (NGL) or have referred an access dispute to arbitration under the NGL.

5. FURTHER INVESTIGATIONS

Further investigations may be required to determine the terms and conditions for provision of a pipeline service sought by a user or prospective user in a manner that is technically feasible and consistent with the safe and reliable operation of the pipeline.

As outlined in Section 4, if further investigations are required to be undertaken prior to responding to the access request, we will outline a proposal to you for carrying out the further investigations (**FEED Proposal**).

The FEED Proposal will include:

- (a) a statement of the nature and scope of work of the investigation;
- (b) a plan (including a time schedule) for carrying out and completing the investigation;
- (c) a statement of the reasonable costs of the investigation you would be required to meet; and
- (d) any other information reasonably required by us for the purposes of the investigation.

We will not carry out the FEED Proposal without first agreeing its contents with you.

The National Gas Rules require a service provider and a prospective user to negotiate in good faith about the terms and conditions on which further investigations will be carried out, including the basis for determining reasonable costs of the further investigations to be paid by the prospective user and any reasonable extension of time to enable the further investigations to be completed.

Where further investigations are required, an access offer will be made within 60 business days after receiving the Complying Access Request unless a later period is agreed between you and us.

6. NEGOTIATION & ARBITRATION

Obligation to Negotiate in Good Faith

If you have notified us that you wish to enter into negotiations with us in relation to the access offer that we make you in relation to your Complying Access Request, we and you as, the prospective user, must negotiate in good faith with each other in accordance with section 148D of the National Gas Law as to whether access can be granted and the terms and conditions for the provision of that access.

During negotiations, each of us must:

- take all reasonable steps to agree to a timetable for the negotiations and, in doing so, each of us must seek to accommodate all reasonable requirements of the other party or parties to the negotiations; and
- use reasonable endeavours to identify any other person who may become a party to an access dispute relating to the pipeline service the subject of the negotiations.

Information Exchange

At any time after we have started negotiations, you may request further information from us, being:

- information about the method used to determine the price in an access offer and the inputs used in the calculation of the price; and
- information regarding the costs associated with the provision of the pipeline services sought by the prospective user (**Access Offer Information**).

You must request the Access Offer Information in writing addressed to the relevant contact person outlined in Section 3 of this guide.

We will comply with a request for Access Offer Information within 15 business days of the date you submit the request in writing (or any longer period agreed with you).

At any time after we have started negotiations, either of us may request the following information of the other party/ies to the negotiations (**Access Negotiation Information**):

- Access Offer Information; and
- any other information that the party may seek to rely on for the determination of an access dispute in relation to the subject matter of the negotiations,

including information prepared for the party such as expert reports and consultant reports, data sets, models and other documents or materials.

Any request for Access Negotiation Information must be made in writing and sent to:

- in the case of a request we make to you – the person who submitted the Complying Access Request;
- in the case of a request we or you make to any party to the negotiation other than you or us – the person we have been dealing with in the negotiations; and
- in the case of a request you make to us – the relevant contact person outlined in Section 3 of this guide.

Each of us must comply with requests for Access Negotiation Information within 15 business days of the date of submitting the request to the other (or any longer period agreed between us).

Neither party is required to provide, in response to a request for Access Offer Information or Access Negotiation Information, an item of information requested by another party under this rule where:

- to do so would breach a confidentiality obligation owed in respect of that information to an unrelated third party; and
- the third party has not given consent to the disclosure despite reasonable efforts having been

made to obtain that consent.

Furthermore, neither party is required to provide, in response to a request for Access Negotiation Information:

- information that is the subject of legal professional privilege; or
- documents that would disclose information subject to legal professional privilege.

In requesting or providing Access Offer Information or Access Negotiation Information, each party must do so in a manner and at a time that is consistent with the duty of the party to negotiate in good faith.

Right to Refer an Access Dispute to Arbitration

During negotiations, either participant may refer an access dispute to arbitration under Chapter 5 of the National Gas Law.

Before a party issues an access dispute notice, it must request the other party to provide all Access Negotiation Information and it must not issue an access dispute notice earlier than 15 business days after the notice requesting all Access Negotiation Information has been given to the other party.

Each party must follow the process for referring an access dispute outlined in the National Gas Law and the National Gas Rules.

7. CONFIDENTIALITY

Any information provided to another party during negotiations (referred to in section 5 or 6) will be treated as confidential information (**Confidential Information**) other than any information that is in the public domain when provided or that subsequently comes into the public domain.

Each of us must only use or reproduce Confidential Information of another party for the purpose for which it was disclosed and we must not disclose the confidential information except:

- to the Australian Energy Regulator or to the arbitrator in the course of an arbitration;
- if an access dispute is mediated – to the mediator;
- with the consent of the other party;
- to a professional or other adviser of the party who agrees with the party to maintain the confidentiality of the confidential information;
- if it is required by, or necessary for the purposes of, the NGR or the NGL;
- if the disclosure is in accordance with an order made or a subpoena issued by a court of competent jurisdiction; or
- if the disclosure is authorised or required by a law of a participating jurisdiction or required by a competent regulatory body, and the person making the disclosure gives written details of the disclosure (including an explanation of the reasons for the disclosure) to the other party.

8. INTERCONNECTION POLICY

Under the National Gas Rules, a service provider must develop and maintain an interconnection policy that relates to the principles applying under Part 6 of the National Gas Rules. The interconnection policy must be published as part of a user access guide.

Appendix B contains the interconnection policy for the service providers identified in section 2, in relation to the pipelines and networks identified in that part.

9. CHANGES TO THIS GUIDE

Under the National Gas Rules, a service provider must publish a revised version of a user access guide for a pipeline as soon as practicable after facts or circumstances arise that require the guide to be updated.

A revised version of this Guide will take effect when published or, if later, when specified in the revised version.

A reference to the Guide includes a reference to the Interconnection Policy that is included as Appendix B to this Guide.

APPENDIX A: ACCESS REQUEST FORM

[Insert Service Provider Name – see Section 2]

ACCESS REQUEST FORM

This is an Access Request Form, in accordance with the User Access Guide. The terms and conditions for the service are subject to negotiation between the Service Provider and the Prospective User.

1. PROSPECTIVE USER DETAILS

Name	
ABN	
Address	
Telephone Number	
Facsimile Number	
Email	
Nominated Representative	

2. DETAILS OF RELEVANT PIPELINE or NETWORK

3. SERVICE DETAILS

Type of Requested Service	Reference Service/Non-Reference Service *** *** DELETE WHICHEVER IS NOT APPLICABLE
---------------------------	---

Requested Service	
-------------------	--

Requested Service Start Date	
------------------------------	--

Requested Service End Date	
----------------------------	--

4. INLET AND OUTLET POINTS

The following are to be the Inlet Points, Outlet Points and Contracted Capacity for Service as at the Capacity Start Date.

ITEM 1: INLET POINTS: DESCRIPTION AND CONTRACTED CAPACITIES

	Location	Designation	Contracted Capacity (TJ/d)
1.			
2.			
3.			
TOTAL:			

ITEM 2: OUTLET POINTS: DESCRIPTION AND CONTRACTED CAPACITIES

	Location	Designation	Contracted Capacity (TJ/d)
1.			
2.			
3.			
TOTAL:			

5. TRANSMISSION PIPELINES

If this request relates a transmission pipeline, please provide details of the delivery temperature and pressure of gas.

	Location	Delivery Temperature	Delivery Pressure
1.			
2.			
3.			

6. CREDITWORTHINESS

The Prospective User represents and warrants that copies of its latest set of audited accounts and (if applicable) its Constitution are attached.

If the Prospective User has a credit rating, the Prospective User should provide details of that credit rating (with this Access Request Form) to enable the credit rating to be assessed against AGIG's Credit Policy.

Executed by Prospective User:

Executed by
[insert Prospective Users Details and ABN] in
 accordance with section 127 of the Corporations Act
 2001:

Signature – Director

Title

Name (block letters)

Signed – Director/Secretary

Title

Name (block letters)

APPENDIX B: INTERCONNECTION POLICY

Table of contents

1. REQUIREMENTS OF A USER ACCESS GUIDE	3
2. WHO ARE YOU DEALING WITH	4
3. CONTACT DETAILS.....	6
Transmission Pipelines	6
Distribution Networks	6
4. ACCESS REQUEST PROCESS.....	7
5. FURTHER INVESTIGATIONS	9
6. NEGOTIATION & ARBITRATION	10
7. CONFIDENTIALITY	12
8. INTERCONNECTION POLICY	13
ACCESS REQUEST FORM.....	15
Background.....	20
Purpose.....	20
Scope.....	20
Interpretation.....	20
Right to interconnect.....	21
Interconnection process	22
Process Summary	22
Distribution Connected Facilities on Victorian Declared Distribution System	22
Required Equipment	22
Gas Quality Standards	24
Gas Quality Monitoring Systems.....	24
How to apply?	25
Step 1 - Provide high level concept	25
Step 2 – Initial enquiry.....	25
Step 3 – Detailed Analysis Study	26
Step 4 – Approvals	27
Step 5 - Connection Offer.....	27
Step 6 - Construction and commissioning.....	27
Step 7 – Sign-offs prior to commencing operations	27
Step 8 – On-going obligations.....	28
Relevant policies.....	29
Gas Quality	29
Heating Value	29
HSE Policies	29

How is your application assessed?	30
Fees	31
Connection Agreement.....	32
Connection Agreement.....	33

Background

Purpose

This Interconnection Policy is made for the purposes of rule 39 of the National Gas Rules by each of the service providers identified in section 2 of the User Access Guide in relation to the pipelines and networks identified in section 2 of the User Access Guide.

Scope

This Interconnection Policy addresses the requirements for a pipeline or other facility seeking to connect to a pipeline or network identified in section 2 of the User Access Guide.

This Interconnection Policy does not limit or derogate from any requirement to gain any permission or authorisation that otherwise applies under the National Gas Law or the National Gas Rules in relation to making a connection to a pipeline⁴.

This Interconnection Policy does not address requirements for the injection of gas into any gas retail market or the declared wholesale gas market.

This Interconnection Policy does not and will not be applied in a way that is inconsistent with the requirements of any pipeline licence, gas distribution licence or gas reticulator's licence or any applicable law.

Interpretation

In this policy, a reference to the Service Provider is a reference to the entity which is the service provider for the pipeline or network to which the reference relates. A reference to a pipeline is a reference to a pipeline or capitalised terms have the meaning given in this Interconnection Policy, or as otherwise defined in the National Gas Law and National Gas Rules.

⁴ See Rule 36(2), National Gas Rules.

Right to interconnect

In accordance with rule 37 of the National Gas Rules, a person has a right to connect a pipeline or other facility to a pipeline (an **interconnection**) where:

- (a) it is technically feasible and consistent with the safe and reliable operation of the pipeline; and
- (b) the person agrees to fund the costs associated with making the interconnection.

In accordance with rule 38(1) of the National Gas Rules, the party seeking to establish the interconnection (the **interconnecting party**) has, subject to rule 37, the option to:

- (a) construct, operate and maintain the interconnection at its own cost (**option A**);
- (b) have the Service Provider do so (**option B**); or
- (c) proceed with a combination of option A and option B if both the interconnecting party and the Service Provider:
 - (i) will own equipment or infrastructure associated with the interconnection; or
 - (ii) agree to share the costs and responsibilities associated with the interconnection.

In accordance with rule 38(2) the National Gas Rules, if the interconnecting party develops the interconnection (or part of the interconnection), it must do so in accordance with good industry practice and comply with all standards and legislation that relate to the establishment and on-going operation of the interconnection and with any reasonable technical, safety and reliability requirements requested by the Service Provider.

Interconnection process⁵

Process Summary

1. Contact the Service Provider
2. Provide concept details and discuss high-level feasibility
3. Engage in detailed analysis study
4. The Service Provider makes connection offer
5. The Service Provider and interconnecting party agree to connection offer and enter into necessary legal agreements
6. The Service Provider and interconnecting party obtain all approvals
7. Construction and commissioning
8. Complete testing and gain final injection approval from the Service Provider
9. Commence operations
10. Comply with on-going obligations

Distribution Connected Facilities on Victorian Declared Distribution System

Required Equipment

In the case of distribution connected facilities that wish to connect to the Victorian declared distribution system, AEMO will make gas quality monitoring procedures that will determine the required gas quality monitoring equipment⁶. Interconnecting parties are encouraged to discuss these requirements directly with AEMO, and in consultation with AGN if required.

At a high level, noting that the required equipment depends on the type of distribution connected facility seeking an interconnection, we set out below examples of the equipment likely to be required. Note that project proponents should undertake detailed design and these requirements may vary.

⁵ Rule 39(2), National Gas Rules, requires the Interconnection Policy to describe the interconnection process, starting at the application stage through to the point of commencing operations using an interconnection and to set out the information to be provided in an application by a person seeking to establish an interconnection, and the information each party will then provide to each other in the course of the process associated with establishing an interconnection.

⁶ See rule 85, Part 17, Schedule 1, National Gas Rules.

Biomethane Injection Facility

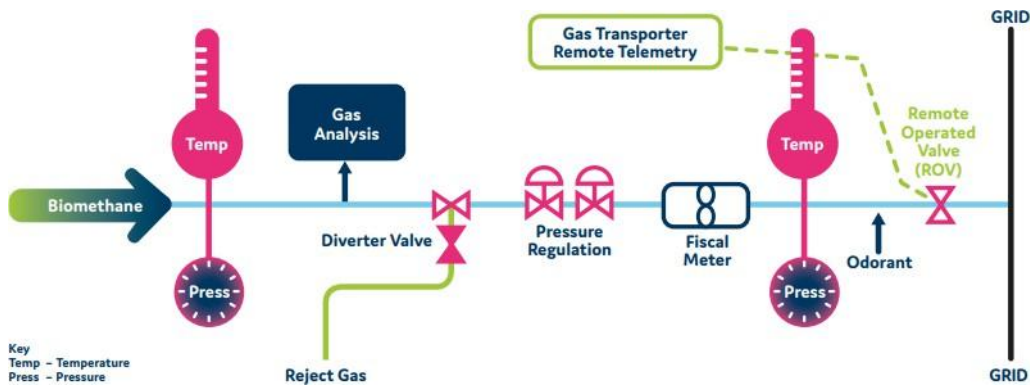

Hydrogen Blending Facility (direct blending)

In this process hydrogen is blended directly into an existing gas supply main and gas quality and flow measurement equipment is installed downstream of the blending point.

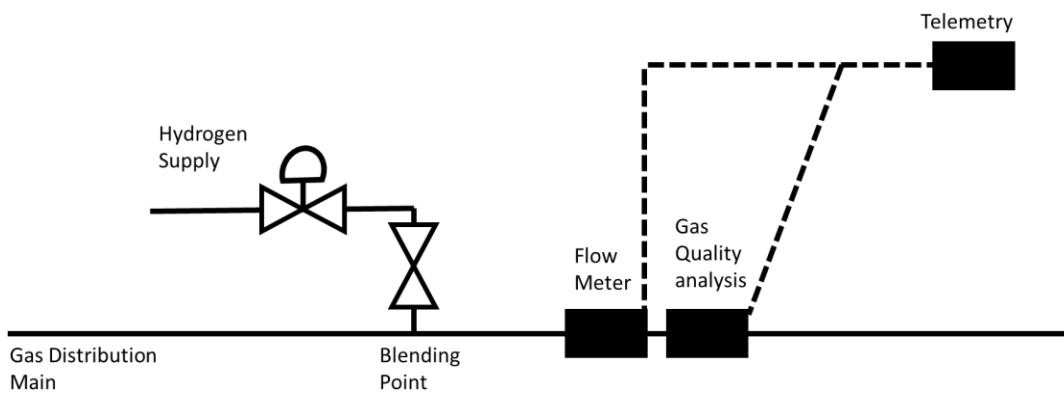

Hydrogen Blending Facility (indirect blending)

In this process the normal flow of gas is diverted out of the existing gas supply main through the blending facility.

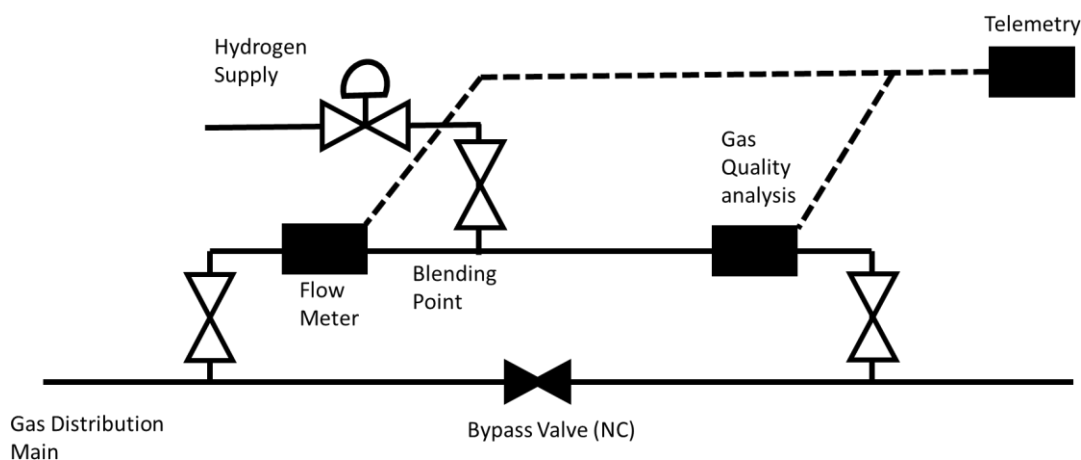

Gas Quality Standards

In the case of distribution connected facilities that wish to connect to the Victorian declared distribution system, under the NGR, with effect from 1 May 2024, a distribution connected facility operator may request a distributor to enter into an agreement that sets out the quality standard that will apply to gas that does not comply with the standard gas quality specifications⁷.

In addition, interconnecting parties must comply with AGN's policies (see section 5 of this Policy) and any other requirements of AEMO.

Gas Quality Monitoring Systems

In the case of distribution connected facilities that wish to connect to the Victorian declared distribution system, with effect from 1 May 2024, gas quality monitoring systems will be required by Part 19 of the National Gas Rules to monitor gas quality at the injection point, where gas from a distribution connected facility passes into the declared distribution system.

With effect from 1 May 2024, AEMO will make the gas quality monitoring procedures which, amongst other things, will provide for gas quality monitoring requirements and the equipment to be included in gas quality monitoring systems⁸.

At a minimum, a gas quality monitoring system must meet the requirements of rule 289G.

The National Gas Rules will require a person to act as the responsible gas quality monitoring provider for a DDS injection point.⁹

The responsible gas quality monitoring provider is responsible to establish and maintain a gas quality monitoring system and gas quality monitoring plan that satisfies the requirements of the National Gas Rules¹⁰. If AGN is not the responsible gas quality monitoring provider, these arrangements will need to be approved by AGN¹¹.

The gas quality monitoring arrangements have to be established before gas can be injected at the injection point (unless AEMO gives express permission to supply gas before those arrangements have been established)¹².

⁷ Rule 287A, National Gas Rules (to be introduced by the National Gas Amendment (DWGM distribution connected facilities) Rule 2022 No 3, effective 1 May 2024).

⁸ Under the transitional rules, AEMO is required to make these procedures available by 1 February 2024 ((see the transitional provision in rule 85, Part 17, Schedule 1 to the NGR).

⁹ Rule 289C, National Gas Rules (to be introduced by the National Gas Amendment (DWGM distribution connected facilities) Rule 2022 No 3, effective 1 May 2024).

¹⁰ Rules 289E, 289G and 289H, National Gas Rules (to be introduced by the National Gas Amendment (DWGM distribution connected facilities) Rule 2022 No 3, effective 1 May 2024).

¹¹ Rule 289E(2), National Gas Rules (to be introduced by the National Gas Amendment (DWGM distribution connected facilities) Rule 2022 No 3, effective 1 May 2024).

¹² Rules 289E(3) and 289F(1), National Gas Rules (to be introduced by the National Gas Amendment (DWGM distribution connected facilities) Rule 2022 No 3, effective 1 May 2024).

How to apply?

Step 1 - Provide high level concept

Project proponent to develop a high-level concept of the project to enable further steps.

High-level concept must include the details set out below, and must be recorded on an Injection Enquiry Form (available here: <https://www.australiangasnetworks.com.au/our-business/regulatory-information>)

Details:

- Project proponent contact details
- Project location
- Type of gas that is to be injected at the interconnection point (natural gas, biomethane, hydrogen or otherwise) and specifications for that gas
- Source of input (e.g. type of biogas feedstock, or source of water for hydrogen electrolysis)
- Relevant technology used
- Concept level capital and operating costs
- Expected flow rate

In addition, if known to the project proponent, the project proponent is encouraged to advise AGN whether the interconnecting party wishes to construct, operate and maintain the interconnection at its own cost (Option A) or have the distributor do so (Option B) or some combination of Options A and B.

Step 2 – Initial enquiry

Contact AGN via email at the following addresses, with completed Injection Enquiry Form, including the data identified in Step 1.

Victoria and Southern NSW – Damien Skafte (Damien.skafte@agig.com.au)

South Australia – David Holden (David.Holden@agig.com.au)

Queensland – Kristian Abandowitz (Kristian.Abandowitz@agig.com.au)

AGN will perform a high-level analysis and mapping to assess whether an interconnection is possible. If AGN will incur a charge to undertake this high-level analysis and mapping, AGN may advise the project proponent of such charges and require the project proponent to reimburse AGN for such charges.

Once the initial enquiry and high-level analysis and mapping is complete, AGN will provide the proponent with a capacity assessment and advise the project proponent of any potential issues.

TIMESCALE: 15 working days

As part of this process, AGIG can provide the following information to assist the proponent with its feasibility assessments:

1. Location and type/size of nearest appropriate distribution main (in the case of a connection to a network)
2. Information about equipment required to connect to the pipeline
3. Information on required data sharing arrangements
4. Information on required gas quality

Step 3 – Detailed Analysis Study

Project proponents must engage with AGN to complete detailed analysis studies (**DAS**). If AGN will incur a charge to undertake this work, AGN may advise the project proponent of such charges and require the project proponent to reimburse AGN for such charges.

The DAS will provide proponents with further information in relation to the following matters (as relevant):

- Injection point options
- Pipeline capacity flows and constraints
- Indication of costs for the Service Provider to carry out the pipeline construction, augmentation and connection
- Indication of costs for the Service Provider to procure and install the injection facility
- Plant and equipment required to be provided by the interconnecting party
- Details of proposed site and pipeline route
- Gas Quality risk assessment
- Injection Constraints, Injection pressure etc
- Quote of estimated costs of interconnection

Project proponents must review and satisfy themselves as to the content of the DAS and advise the Service Provider if they intend on proceeding with the interconnection.

Following DAS, project proponents will need to undertake a detailed front end engineering design.

At this stage, if a project proponent has not done so already, the project proponent needs to make an election for the purposes of rule 38(1) as to whether the interconnecting party wishes to construct, operate and maintain the interconnection at its own cost (Option A) or have the service provider do so (Option B) or some combination of Options A and B.

Irrespective of which option is taken, the service provider must be consulted and involved in the HAZOP or any other formal safety assessment (including preparing a safety case or safety management system) for the facility or for the interconnection.

TIMESCALE: 2 - 12 months depending on complexity.

Step 4 – Approvals

If, following the DAS, the project proponent wishes to proceed with the interconnection, the project proponent must obtain any necessary approvals or consents required under the National Gas Law, National Gas Rules or any other applicable laws, or otherwise, and provide evidence of such approvals being obtained on the Service Provider's request.

The Service Provider may also require approvals or consents in relation to the proposed interconnection and the Service Provider will obtain these approvals or consents during this stage (or during later steps).

In cases where a distribution connected facility wishes to connect to the declared distribution system in Victoria, if the Service Provider is not the responsible gas quality monitoring provider for the interconnection, the gas quality monitoring arrangements for the injection point are required to be approved by the Service Provider before gas can be injected at the injection point (unless otherwise agreed with AEMO). In this case, the Service Provider will require the project proponent to provide the Service Provider with details of the proposed gas quality monitoring arrangements for approval during Step 4.

Project proponents will be required to procure any required land access needed by the Service Provider in order to facilitate the interconnection and undertake any on-going operation and maintenance of the distribution connected facility or any required mains extensions.

Step 5 - Connection Offer

If the project proponent wishes to proceed with the interconnection and has provided written confirmation of this intention and any evidence requested by the Service Provider in accordance with step 4.4, the Service Provider will provide the following legal agreements (and any others that may be required, determined on a case by case basis) as soon as reasonably practicable:

- (a) A connection offer and related Connection Agreement (as described in section 8);
- (b) In cases where a distribution connected facility wishes to connect to the declared distribution system in Victoria, a rule 287A agreement (if requested by the distribution connected facility operator to allow the injection of gas that does not comply with the standard gas quality specifications).

It is anticipated that the connection offer will include information pertaining to each parties' role and responsibilities, notice of any further design work required and options for the Service Provider led or proponent led construction, installation, testing and commissioning processes.

Step 6 - Construction and commissioning

Construction and commissioning will be undertaken by the responsible party, as designated in the connection offer.

Step 7 – Sign-offs prior to commencing operations

Prior to commencing operations, the Service Provider will undertake an assurance process. Project proponents will be required to assist and cooperate with the Service Provider to undertake this assurance process, and provide any information reasonably requested by the Service Provider for these purposes.

Project proponents will need to provide the results of on-site testing of all equipment (including any pipeline or distribution connected facility), to demonstrate that it has been installed correctly and it is fit for purpose.

The Service Provider will verify the on-site test results once completed and may request a right to observe any such tests, or may undertake further testing as it deems required, including but not limited to testing to check that the signals being sent to the Service Provider's control room are fully operational.

The Service Provider may require project proponents to carry out gas sampling on natural gas, raw biogas hydrogen or other gases in line with a sampling protocol to be agreed during any gas quality risk assessment meetings that occur during the design stage. The Service Provider must be satisfied (in its absolute discretion) that gas meets the quality requirements before proceeding with commencing interconnection.

The Service Provider will advise the project proponent of any sign-offs or approvals required to be obtained prior to commencing the interconnection.

Step 8 – On-going obligations

The Service Provider will carry out project financial reconciliation and provide feedback to proponents. The Service Provider may require project proponents to provide any appropriate project document records to allow completion of the reconciliation process and a project close out meeting should be held.

For the life of the interconnection, project proponents will, amongst other things, need to provide the Service Provider:

- Contact details for both emergency contact (outside of business hours) and operational contact (during business hours)
- calibration files
- planned maintenance schedule (at least annually or as otherwise agreed)
- gas sampling test results to the timescales outlined in your sampling protocol
- test results associated with the measurement equipment
- details of any unplanned outages
- responses to any inspections associated with the pipeline or facility

TIMESCALE: Project closure meetings should be carried out within 6-8 weeks of commissioning

Relevant policies¹³

Project proponents must comply with the requirements of the Connection Agreement, any agreement entered into for the purposes of Rule 287A, any policies and procedures required by AEMO, and the following policies (where relevant):

Gas Quality

Refer to AGIG-EG-RG-001 – Biomethane Gas Quality Requirements

Available here: <https://www.australiangasnetworks.com.au/our-business/regulatory-information>

Heating Value

Refer to AGIG-EG-RG-001 – Biomethane Gas Quality Requirements

Available here: <https://www.australiangasnetworks.com.au/our-business/regulatory-information>

HSE Policies

Health & Safety Policy

Environment Policy

Fitness for Work Policy

Zero Harm Principles

Available here: <https://www.agig.com.au/health-safety-and-environment>

¹³ Rule 39(2)(d) requires the Interconnection Policy to provide a link to any of the service provider's policies that are relevant to establishing an interconnection policy.

How is your application assessed?¹⁴

Interconnection applications will be assessed by the Service Provider on a case by case basis.

The primary assessment criterion is whether the interconnection is technically feasible and consistent with the safe and reliable operation of the pipeline or network and the safe and reliable supply of gas to end users.

All project proponents must also satisfy the Service Provider that it will comply with good industry practice and all standards and legislation that relate to the establishment and ongoing operation of the interconnection and any reasonable technical, safety and reliability requirements requested by the Service Provider.

¹⁴ Rule 39(2)(e), National Gas Rules requires the Interconnection Policy to include a description of any technical, safety or reliability principles, requirements or processes that the service provider will use to assess an interconnection application.

Fees¹⁵

Interconnection fees, fees for connection works and ongoing interconnection services will be calculated on a case by case basis. The terms of payment of any such fees will be set out in the relevant agreement.

If the Service Provider develops the interconnection (or apart of the interconnection), the interconnection fee will be based on the directly attributable cost of constructing, operating and maintaining the interconnection, to the extent that this is undertaken by the Service Provider, including so as to achieve a rate of return calculated in accordance with the applicable rate of return instrument (in the case of a scheme pipeline) and a commercial rate of return that reflects the pricing principles set out in rule 113Z(4) of the National Gas Rules (in the case of a non-scheme pipeline)¹⁶.

Payment of application assessment charges may be considered in determining applicable interconnection fees.

The National Gas Rules may also require a participant to pay other costs¹⁷, particularly if an interconnecting party is not the responsible gas quality monitoring provider or responsible person for a metering installation.

¹⁵ Rule 39(2)(f), National Gas Rules requires the Interconnection Policy to set out information about how interconnection fees will be calculated and recovered (taking into account the requirements under rule 38(3)).

¹⁶ See rule 38(3), National Gas Rules.

¹⁷ For example, in the case of a distribution connected facility, see rules 289E(5), 299(13) and 313, National Gas Rules. Rule 289E(5) will be introduced by the National Gas Amendment (DWGM distribution connected facilities) Rule 2022 No 3, effective 1 May 2024.

Connection Agreement

Rule 39(2)(g), National Gas Rules, requires the Interconnection Policy to set out the standard terms and conditions of any connection agreement that the Service Provider may require an interconnecting party to enter into - please see Schedule, Connection Agreement.

The Connection Agreement sets out the standard terms and conditions that AGN may require an interconnecting party to enter into.

Connection Agreement